

KNIGHT

TRAILBLAZER

TRAILED SPRAYERS

MAXimizer PRO

GOLD MEDAL FOR INNOVATION



01780 722202

www.knight-ltd.co.uk

sales@knight-ltd.co.uk

DESIGNED WITH **YOU** IN MIND

The Knight family started their sprayer business in 1984 driven by the need for a high quality, advanced trailed sprayer. This passion continues within the business today delivering these values to today's agribusinesses

Our latest Trailblazer machines bring you the very latest in spray application technology, incorporated into industry leading boom and chassis suspension system, machine strength and durability.

YOUR KEY TO SUCCESS!

Look out for these icons as a quick reference to how each Knight feature benefits YOU!



Accurate Application



Comfortable



Simple to Use



Saves you Money



Eco-friendly



High Output





KNIGHT TRAILED SPRAYER MODELS

DESIGNED TO HELP YOU GROW.

TRAILBLAZER L

- Entry level machine with Gullwing boom & MAXImizer PRO plumbing
- Smart 430 terminal
- Self-levelling air-suspension rear axle

TRAILBLAZER S

- As per trailblazer Lite with
- Electro-hydraulics
 - Touch 800 terminal

TRAILBLAZER PRO

- As per trailblazer with
- Pro electro-hydraulic system
 - Rear mounted hydraulically driven sprayer pump
 - Sprung drawbar

SPRAYER FEATURES



DRAWBAR & CHASSIS

Knight sprayers have always led the field with their advanced chassis design. Our latest Trailblazer range continue in this vein with an air suspended axle and the following range of drawbar options.



- Cushioned drawbar
- Continental hi-hitch
- K80 ball coupling
- Linkage drawbar



REAR AXLE

STEERING



Trailblazers are available with rear axle steering which is gyroscopically controlled to ensure the sprayer perfectly tracks behind the tractor.

BRAKING



- Hydraulic braking is standard, with air braking available as an optional extra. A combination of both is also possible.
- High performance axles are fitted throughout the Trailblazer range
- High speed axles with ABS braking are available as an optional extra.



SUSPENSION



- All Trailblazer sprayers are fitted with load sensing air-suspension. This combination precisely maintains the machines working height and stability.
- For machines fitted with air-brakes, load sensing is also employed to ensure safe and accurate braking.



HILLSIDE ALIGNMENT



The sprayer automatically compensates when working on hill sides by steering the axle to ensure the wheels stay in the tramlines.

WHEEL EQUIPMENT



Please refer to specification matrix at the end of the Trailblazer brochure.



SPRAYER FEATURES



TANKS & STORAGE

We pride ourselves in being able to offer customers exactly what they require. Trailblazer sprayers can be ordered with rotational moulded or stainless-steel tanks with capacities from 3,600 litres up to 12,000 litres.

CLEAN WATER TANK



All Trailblazers are fitted with clean water tanks containing more than 10% of the spray tank. Clean water tanks are filled independently to avoid contamination from the chemical system. The optional clean water tank fill uses an independent pump which automatically tops up the wash tank whenever the operator is filling the main tank allowing them to focus on filling with product.

STORAGE LOCKERS FOR PPE CLOTHING AND SPARE PARTS



Trailblazers have storage lockers strategically located around the machine for maximum operator convenience. The all-important PPE locker is located by the chemical filling station and includes separate compartments for clean and used items. Parts can be stored in a removable toolbox and spare nozzles can be stored in on-boom storage boxes to minimize down time.

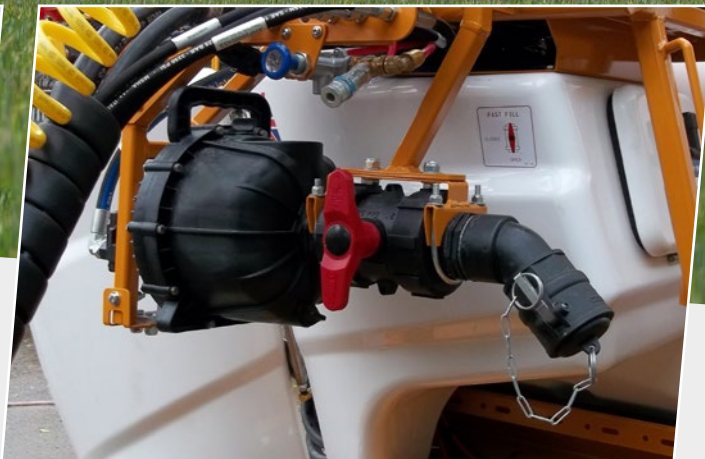

PUMPS & PRESSURE CONTROL

MAIN PUMP - STANDARD



All Knight sprayers use multi cylinder diaphragm pumps to supply the main spray system. We use this type of pump for their simplicity, reliability, and ability to deliver consistent pressure and flow, on a linear basis, ensuring accurate product applications at all times.

FAST FILL PUMP – OPTIONAL



For customers requiring a faster fill than the standard pump provides, we offer two alternative pumps to boost fill capacity.

- ➔ High capacity diaphragm pump
- ➔ High capacity, hydraulically driven centrifugal pump

RAMSEY VALVE – SYSTEM PRESSURE CONTROL



Knight sprayers use a Ramsey diaphragm valve to regulate application pressure. We have used this valve for many years because it significantly reduces the workload of the sprayers electronic application control system and improves the accuracy of product application.

SPRAYER FEATURES

MAXimizer PRO

GOLD MEDAL FOR INNOVATION



CIRCULATION & FILLING

Knight were the first in the industry with full product circulation that produced an instant start in the field. They have continued to pioneer advanced sprayer control and circulation and today Knight sprayers use the patented MAXimizer PRO fluid control system that keeps the entire fluid system moving during filling and agitation which prevents dead spots. This system also flushes the entire system with clean water during filling for the ultimate in machine cleaning.



TANK WASH SYSTEM



The spray tank has multiple wash heads for efficient cleaning at the end of the job. When incorporated with the Active Rinse system they can be operated independently of the chemical system for the ultimate in-field clean out including on-the-go rinsing to make sure the last drop of your chemical goes on the crop.



TANK AGITATION



All trailblazers feature two stage spray tank agitation that automatically selects high flow during product mixing and reduced flow when finishing the job. This gives the best possible use of expensive chemicals.

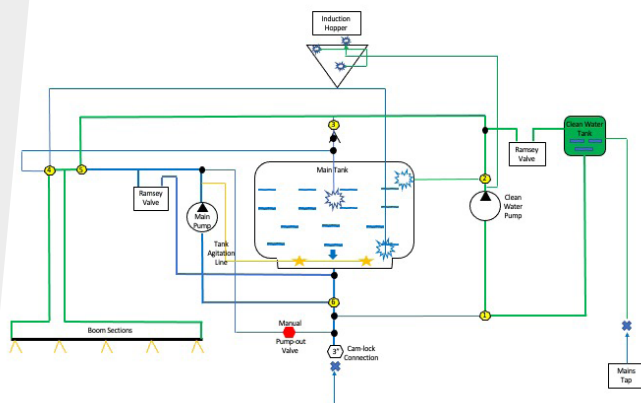

ACTIVE-RINSE – OPTIONAL EXTRA



Active-Rinse is another plumbing and circulation innovation from Knight Sprayers. It features the addition of a high flow pump in the clean water system. During the fill cycle the system automatically fills the clean water tank and provides pressurised clean water at the induction hopper for rinsing containers. It can also be used for high-speed main tank filling. During spraying, as the tanks empty to its last few litres Active Rinse can be set to wash the tank walls, ensure residual chemical is kept to an absolute minimum. The system will also rinse the spray lines with clean water before folding and transport and returns the clean water to the spray tank ready for the next load.

BLOW-OUT – OPTIONAL EXTRA



Using the sprayers compressor system, we have the ability to clean out the product suction pipe from the cam-lock connection to the supply source tap. The compressed air pushes the product back up the supply line so the operator can have a much cleaner and safer disconnecting operation. The system also allows blow out of the sprayer pipe work when required.

MAXIMIZER PRO PLUMBING



The MAXImizer PRO pressurised circulation system ensures a continuous pressurised flow throughout the entire plumbing system to keep product in dilution. It ensures that the spray lines are always charged with dilute chemical at the target application pressure, ready for action.



SPRAYER FEATURES

INDUCTION HOPPERS

The Knight chemical induction system forms an integral part of MAXImizer PRO fluid control which automatically rinses and cleans the induction hopper pipes and valves after use. The latest Whirlpool hopper provides continuous rinsing and agitation during chemical filling which always keeps the bowl as clean as possible. The press-on container rinsing nozzle will easily clean larger 20 litre containers even with stubborn chemicals.



STANDARD



- 25 litre capacity
- Stainless steel construction
- Hinged lid with can drain facility
- Hopper rinse ring
- Twin can wash heads
- Can wash hand lance

WHIRLPOOL - OPTIONAL



- 30 litre capacity
- Circular design for improved cleaning
- Hinged lid with can drain facility
- Continuous hopper rinsing
- Can wash head
- Can wash hand lance



BOOMS & BOOM HEIGHT CONTROL



At Knight Sprayers we cater for all customer requirements and pride ourselves on the quality and durability of our sprayer booms.

→ V-FOLD – UP TO 30M

Available as an option on the Trailblazer range

→ 4-SERIES – UP TO 28M

Standard on the Trailblazer Pro and optional on all Trailblazers sprayers up to 28m

→ TRI-FOLD – 24 TO 40M

Optional on all Trailblazers up to 28m and standard up to 40m

→ 4D BOOM SUSPENSION

The Knight 4D boom suspension system offers an extra dimension in boom stability by isolating a fourth dimension of sideways movement. The system also offers exceptional boom stability in roll and yaw.

→ AUTO BOOM LEVELLING

We offer a fully automatic boom levelling and height control integrated into the spray controller. All 4-series, V-fold and Tri-fold booms have the option of both negative and positive boom inclination.

→ AIR-SLEEVE BOOMS ARE ALSO AVAILABLE

→ OPTIONAL NOZZLE LIGHTING MAKES LONGER WORKING DAYS POSSIBLE

SPRAYER FEATURES

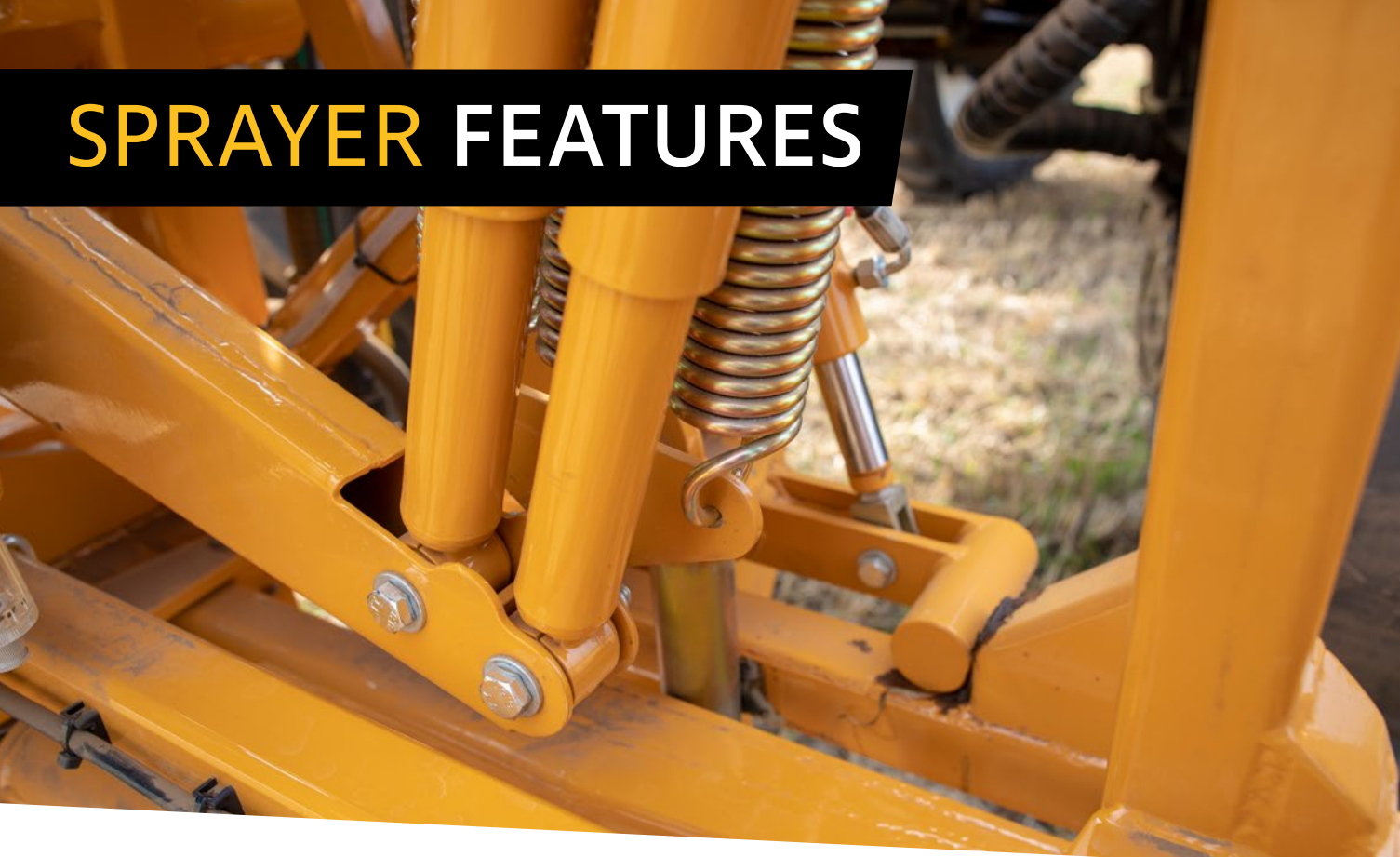

Position adjustable boom mounted sensors are used for boom height & inclination control

BOOM CONTROL

INDEPENDENT LEFT & RIGHT, VARIABLE GEOMETRY, BOOM LEVELLING

4-DIMENSIONAL DAMPENED BACK FRAME

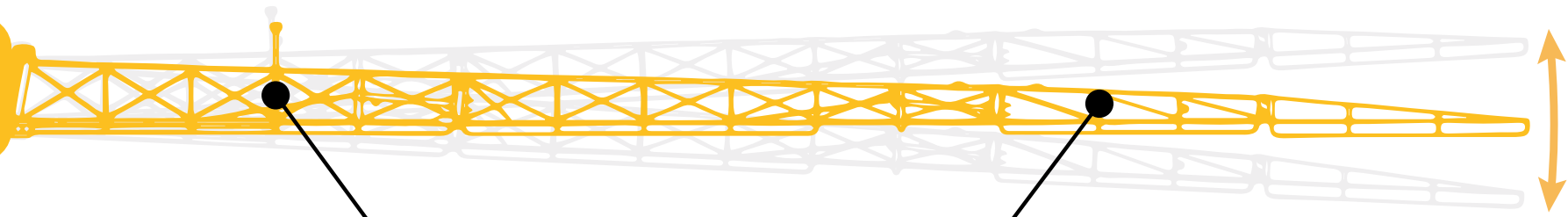

TWO DC2 BOOM LEVELLING SENSORS ON LEFT AND RIGHT BOOM

MAXimizer PRO



GOLD MEDAL FOR INNOVATION



SPRAYER FEATURES



AUTO BOOM LEVELLING

DC1



Mode 1: Raise/Lower Back Frame Levelling



Mode 2: Raise/Lower Synchronised Wing Control

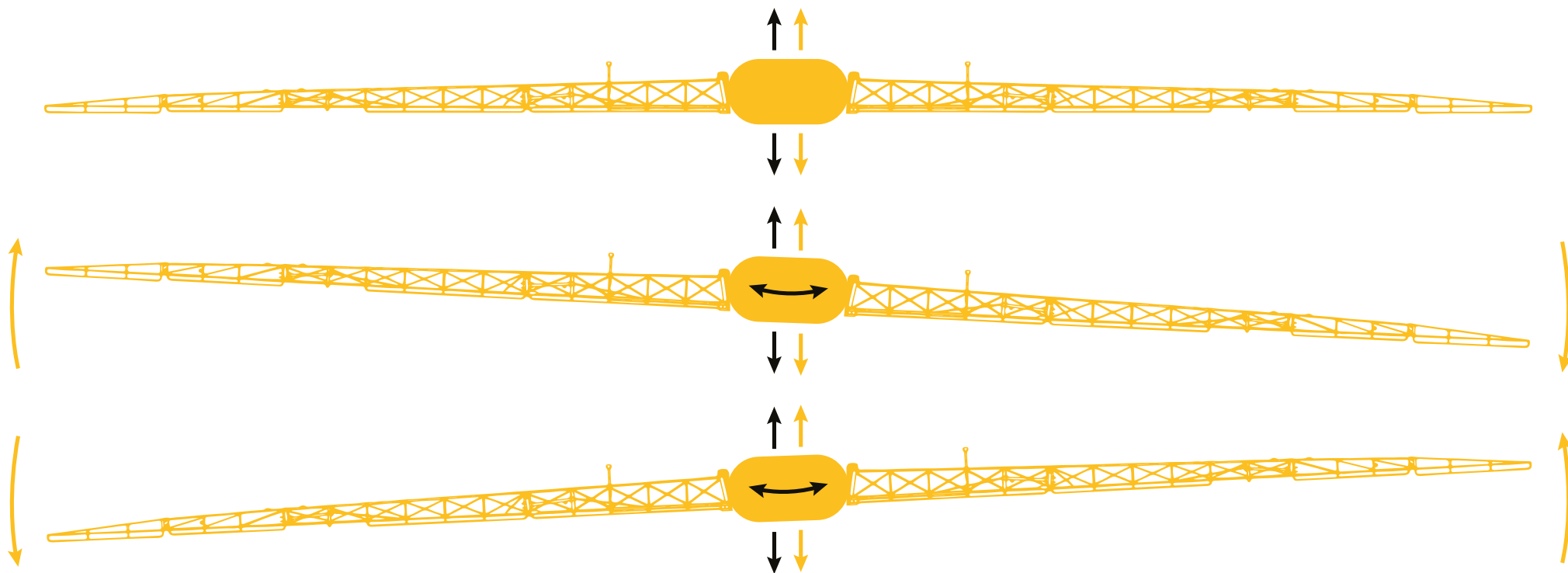

DC2

↑ **Mode 1:** Raise/Lower Back Frame Levelling

↑ **Mode 2:** Raise/Lower Independent Wing Control

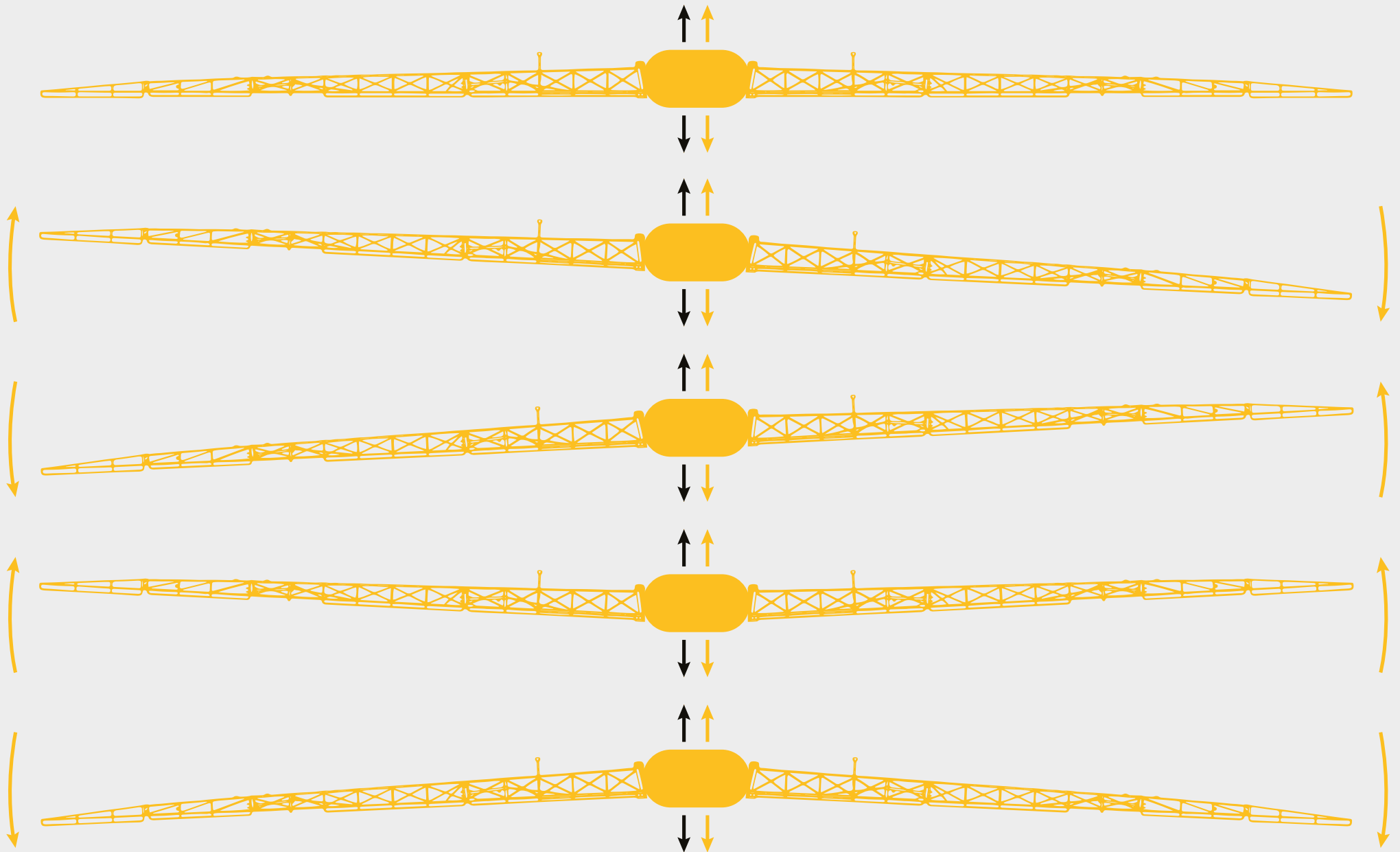

SPRAYER ISO-BUS CONNECTIVITY

ALL KNIGHT SPRAYERS ARE FULLY ISO-BUS COMPATIBLE

Information can be displayed across multiple screens if the base machine is equipped with this facility.



ISO-BUS means that any ISO-BUS component this side of the line will plug and play with the sprayer, giving full fleet integration

ISO-BUS

Having an ISO-BUS sprayer means that any ISO-BUS component on this side of the line will plug and play

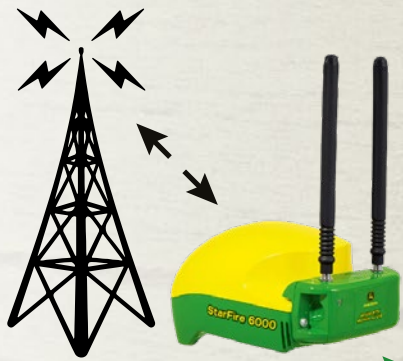

Data transfer between

- Corrective station
- Information carrier
- Machine and office

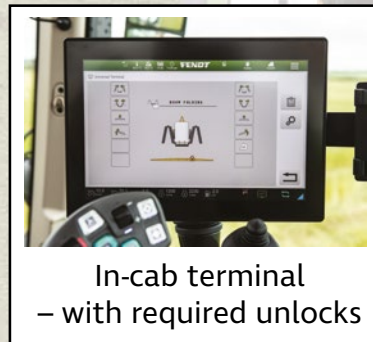

Positional information is passed between the GPS receiver > in-cab terminal > ISO-BUS controller > steering valve and section controller

Steering Valve

- All of the sprayers architectural information resides on a controller as part of the spray pack
- The controller provides this information in an ISO standard format to the in-cab terminal
- The in-cab terminal displays this information to the operator



Command instructions and positional information are passed back and forth between the ISO-BUS controller, the in-cab terminal and the component controllers



SPRAYER TECHNOLOGY

4200 TRAILBLAZER

The latest technology is always at the fore front of our thinking at Knight Sprayers. Whether it's chemical application related or machine and field management related, we have a precision farming system to deliver your particular requirements.

GPS STEERING & CONTROLLER OPTIONS:

Our fully integrated ISOBUS operating system will connect directly to your ISOBUS compatible tractor to form a fully integrated unit.



Trimble



Topcon



Ag Leader



John Deere



NOZZLE BODY & SPRAY LINE OPTIONS:

- Single line – 25mm polished stainless-steel pipework
- Single nozzle
- Triple nozzle
- Quin nozzle
- Quad nozzles plus Vario-select switching
- PWM control
- Individual nozzle on/off

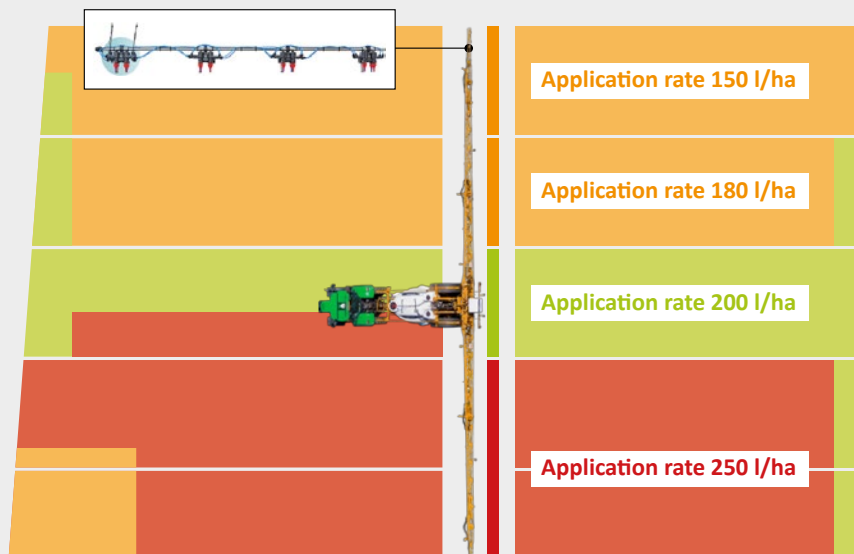

NOZZLE SWITCHING OPTIONS:

→ STANDARD

Uses the sprayer controller to switch section on/off – can be GPS controlled

→ VARIO-SELECT – GPS CONTROLLED

Uses the sprayers controller for: -

- ⇒ Section on/off
- ⇒ Nozzle/cluster on/off
- ⇒ Variable rate of individual nozzle/cluster (+/-)
- ⇒ Execution of variable rate application maps from your Farm software package

NOZZLE TECHNOLOGY

MAXimizer PRO

GOLD MEDAL FOR INNOVATION



SINGLE, TRIPLE, QUIN



VARIO-SELECT



PULSE WIDTH MODULATION (PWM)



SPRAYER SALES, SERVICE & SUPPORT

From choosing your new machine, to aftersales service and support you can always rely on the customer focused team at Knight Farm Machinery.

SALES

When purchasing your new Knight sprayer you can count on expert sales support and advice from our technical sales team and our specialist dealers. We can help you create a new machine specification to suit your exact needs.

From our purpose built headquarters in Rutland, UK we can custom build a machine to match your personal specification and with a visit to our factory, you can see your very own machine being built on our production line.

In conjunction with our preferred finance provider we can offer you a competitive way to purchase of your new sprayer including Higher Purchase and Contract Hire.*

*Finance provision is subject to status. Terms and conditions apply.

SERVICE

Knight understand the importance of keeping your sprayer up and running. With the help of our nationwide dealer network, we provide a complete service and maintenance program including full seven day support and NSTS testing.

Our team of fully trained engineers are available for onsite visits to your farm or field with their fully equipped mobile workshop.

PARTS

Our dedicated spare parts department can help you with parts identification and advice to ensure you get your parts quickly and efficiently. Guaranteed next day delivery is offered throughout mainland UK and an out of hours collection service from our factory is available.

KNIGHT
P A R T S S H O P

A variety of parts are available to purchase from our online store:

shop.knight-ltd.co.uk

Technical Information

Trailblazer Option Examples

TANK OPTIONS	3600 litre rotation moulded tank with two 250 litre clean water tanks	■	■	■
	4200 litre rotation moulded tank with two 250 litre clean water tanks	●	●	●
	5200 litre rotation moulded tank with two 250 litre clean water tanks		●	●
	6000 litre rotation moulded tank with three 250 litre clean water tanks		●	●
	7000 litre rotation moulded tank with three 250 litre clean water tanks - to special order		●	●
	8000 litre rotation moulded tank with three 250 litre clean water tanks - to special order		●	●
	Split water tank detergent rinsing system		●	●
BOOM OPTIONS	3-Series horizontal folding Gullwing boom up to 24m	■	●	
	Heavy duty 4-Series boom with two stage folding up to 30m		●	●
	Heavy duty Tri-Fold boom up to 40m		●	●
	DC1 automatic boom height & levelling		●	●
	DC2 automatic boom height & levelling with +/- boom inclination control		●	●
DRAWBAR COUPLING SYSTEM	Linkage drawbar connected to tractor lower link arms	●		
	Conventional drawbar for connection to tractor drawbar or pick-up hitch	■	■	■
	High level continental drawbar for improved crop clearance	●	●	●
	Drawbar suspension		●	●
STEERING SYSTEM	Automatic hydraulic steering axle	■	■	■
	Automatic hillside correction		■	■
SUSPENSION	Two stage Aeon rubber buffers	■		
	Air suspension with self-levelling load compensation		■	■
SPRAYLINES	MAXimizer PRO pressurised, high speed spray line circulation system with instant air shut off	■	■	■
	Single stainless steel line with large choice of single or multiple nozzle bodies - 500mm spacing	■	■	■
	Single line with twin outlets and large choice of single or multiple nozzle bodies - 500mm spacing	●	●	●
	Single line with twin outlets and large choice of single or multiple nozzle bodies - 250mm or 333mm spacing	●	●	●
	Twin line with large choice of single or multiple nozzle bodies	●	●	●
FLUID SYSTEM	Simple, low volume - high output plumbing system with unique Knight MAXimizer PRO fluid control	■	■	■
	Large capacity suction filter with interchangeable elements	■	■	■
	Automatic pressure compensation via Ramsey regulator	■	■	■
	Automatic spray line clean water rinsing system	■	■	■
	Active-Rinse circulatory system with automatic clean water tank fill & fast fill assistance		●	●
	Liquid fertilizer ready	■	■	■

KEY: ■ Base Build Option

● Available Option - At Extra Cost

Technical Information

Trailblazer Option Examples

PUMP	PTO driven 300 litre/minute diaphragm pump. Suitable for chemical or liquid fertiliser application	■	■	■
	PTO driven 460 litre/minute diaphragm pump. Suitable for chemical or liquid fertiliser application	●	●	●
	High capacity centrifugal pump. Suitable for chemical or liquid fertiliser application	●	●	●
	Hydraulic drive from the tractor		●	■
ELECTRONIC CONTROLLER	Muller Smart-Terminal with joystick control for simple section switching and rate control	■		
	Muller Track-Guide 3, GPS section control for operation of all spraying, filling and boom folding functions		■	■
	Muller Touch 1200, GPS section control for operation of all spraying, filling and boom control functions		●	●
	ISOBUS integration to suitably equipped tractor		●	●
	Curve-Control unlock for variable rate application		●	●
REGULATION SYSTEM	Flow based rate controller system for simple setting and accurate application	■	■	■
	Pressure based rate control system for special applications		●	●
	Combined flow & pressure regulation for variable rate application, Vario-Select and individual nozzle control		●	●
FILLING STATION	Ergonomic control layout with single filling control valve	■	■	■
	Chemical induction hopper with continuous circulation, can wash and container draining	■	■	■
	Push button control incorporating in-cab filling, rinse and washing		●	■
	Electronic tank level control with automatic filling and overflow protection		●	■
	Whirlpool induction hopper with individual function control		●	■
NOZZLE BODY OPTIONS	Single nozzle, air actuated	■	■	■
	Triple nozzle, air actuated	●	●	●
	Quin nozzle, air actuated	●	●	●
	Vario-select, variable rate nozzle cluster, 4 nozzle positions air actuated		●	●
	Pulse Width Modulation (PWM) individual nozzle control - electrically actuated		●	●
NOZZLE & CAPS	Customer choice at extra cost	●	●	●
SECTION CONTROL	Up to 18 section shut-off available		●	●
	Individual nozzle control (EDS)		●	●
WHEEL EQUIPMENT	420/85 R38 - boom size, tank capacity dependant	■	■	■
	380/90 R46 Michelin Agribib	●	●	●
	600/60 R38 Michelin Xeobib	●	●	●

KEY: ■ Base Build Option ● Available Option - At Extra Cost



KNIGHT

Company policy is one of continuous improvement and we reserve the right to change specification without notice. Specifications shown include both standard and optional features.

Knight Farm Machinery Ltd
Wireless Hill
South Luffenham
Oakham
Rutland LE15 8NF

☎ 01780 722202

🌐 www.knight-ltd.co.uk

✉ sales@knight-ltd.co.uk

